

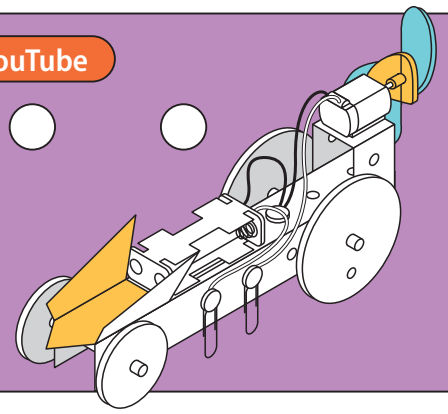

Visit TechCard at techcard.co.uk & Instagram & YouTube

Propeller Car

Propeller Car Skill Level ●●●●●



Build a propeller that generates thrust to propel the car!

Explore how a motor converts electrical energy into mechanical force!

See how to make with TechCard on our website!

The motor converts electrical energy into mechanical force.

The battery stores electrical energy.

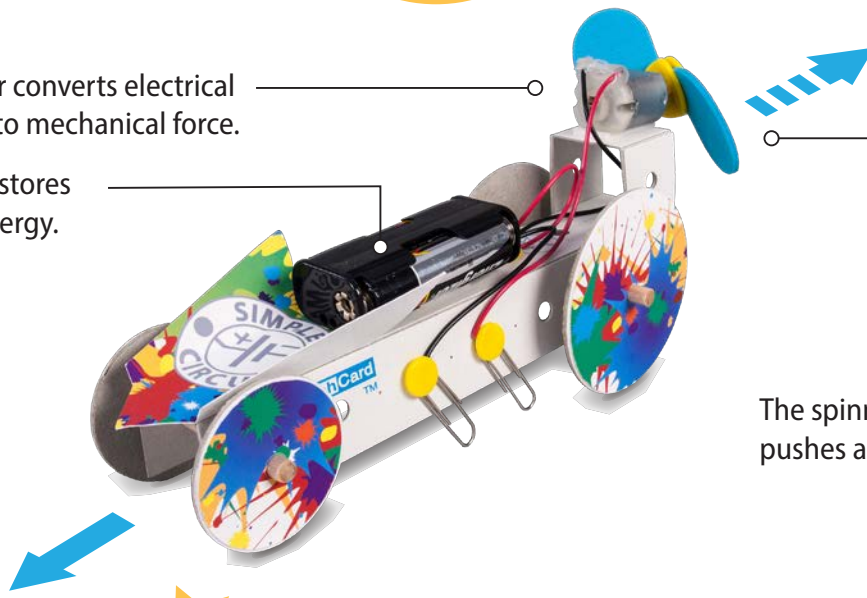

The spinning propeller pushes against the air.

Assembly videos on YouTube!

Parts to make 1 model

Structural Parts		Mechanical Parts	
TechCard Beam	1	60mm Wheel	2
TechCard Strip	1	40mm Wheel	2
		300mm Dowel Axle	1
		Motor	1
		Propeller Hub	1
		Propeller Blade	1
Additional Materials		3V AA Battery Holder	1
1.5V AA Battery	2	Sticky Foam Pads	2
A5 Size Thin Card	1	Rivets and Collars	3
		Paper Clips	2

You will have parts left over towards other models.

Parts to make 10 models

Structural Parts		Mechanical Parts	
TechCard Beam	20	60mm Wheel	20
TechCard Strip	4	40mm Wheel	20
		300mm Dowel Axle	5
		Motor	10
		Propeller Hub	10
		Propeller Blade	10
Additional Materials		3V AA Battery Holder	10
1.5V AA Battery	20	Sticky Foam Pads	20
A5 Size Thin Card	20	Rivets and Collars	30
		Paper Clips	20

Based on pupils sharing off-cuts between them.

Using Batteries Safely



Important! Please read these guidelines before using the Workshop Pack

What is a battery and how do they work?

Batteries are a common part of our everyday lives but it's important to understand how they work to use them safely in circuits that we build ourselves.

A battery is basically a little power station. When a circuit is switched on, chemical compounds inside the battery react and electrical energy (electricity) is generated which flows through the circuit.

A battery has two terminals which are often positioned one at each end of the battery. When a circuit is switched on, electrical energy flows from one battery terminal through the various components in the circuit and back to the other terminal of the battery.

It is important to remember that electricity flows in a 'circuit'. It doesn't just fall out of the ends of a battery! The terminals of a battery have to be connected in some form of circuit before electricity is generated by the battery.

In normal use, the energy in the circuit flows through components which consume the energy. For example, electrical energy flowing through a motor is consumed as the motor converts the electrical energy into a useful mechanical force. The motor will continue to run until the chemical compounds in the battery are depleted and can no longer produce electrical energy.

Problems occur with batteries when what is called a 'short circuit' occurs. A short circuit occurs when the terminals of a battery (or any power supply) are connected without anything in the circuit to use the energy. When a short circuit occurs, electrical energy still flows from one terminal to the other but there is nothing in the circuit to use the energy. As a result, the energy is converted into heat inside the battery and the battery can become dangerously hot. Hot enough to cause a painful burn.

Sometimes more than one battery is used to power a circuit to increase the voltage. For example two 1.5 volt batteries can be used together to generate 3 volts. The rules are the same for circuits powered by a series of batteries as for those powered by a single battery.

How to prevent a short circuit.

There are three likely ways a short circuit can occur. The first is if the battery is inserted in the battery holder before the battery holder is incorporated into the circuit. In this case, the wires from the battery holder can touch and cause a short circuit. The second is if the circuit has not been assembled correctly and electrical energy flows from one battery terminal to the other without being properly connected to the components intended to use the energy. The third is if a piece of conductive material comes into contact with the circuit and allows the electricity to bypass parts of the circuit creating a direct route from one battery terminal to the other.

Conductive materials are materials that electricity can flow through. Most metals are conductive no matter what form they take. For example a metal foil food tray is just as conductive as a piece of wire. Most other materials such as wood, paper, plastic and stone are not conductive.

Keep other conductive materials away when building and do not use conductive materials for decorating or developing the models. Examples of conductive materials that pupils might find to use but should not be used are wire of various kinds and paper clips (apart from those supplied with the kit) paper fasteners and drawing pins, metal tins, foil packaging, aluminium foil, pipe cleaners, wire wool and any other items that may have a metal or conductive surface or coating.

If at any point a short circuit is suspected then disconnect the batteries immediately, allow components to cool and investigate. Be careful to store batteries safely so that they cannot short circuit when not in use.

Using the Workshop Pack

Discuss the safe use of batteries with your pupils explaining that, like many familiar things, they can be dangerous if misused. Teachers should remember to check circuits are assembled correctly before batteries are fitted, not to allow other conductive materials to be used when making powered models and to store and dispose of batteries safely. There are detailed instructions at the end of the model assembly instructions for the installation of batteries which must be followed.

Teachers should also check that models are assembled correctly and supervise their use. Axles, and other mechanical parts, should revolve freely so as not to slow the motor. Obstacles must not obstruct the motor and prevent the motor axle from turning when it is powered as this can cause the electrical components to become hot.

Building simple circuits and using batteries is part of the curriculum and an important learning experience. Building simple circuits and making powered models is an ideal way to demonstrate important topics in the science and technology curriculums and makes learning engaging, memorable and fun!

Make the Propeller Car



Before you start see
'Make with TechCard'
on our website.

1 Make the chassis.

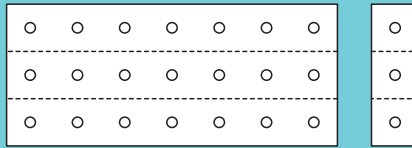

Cut a 175mm beam
and a 25mm beam.

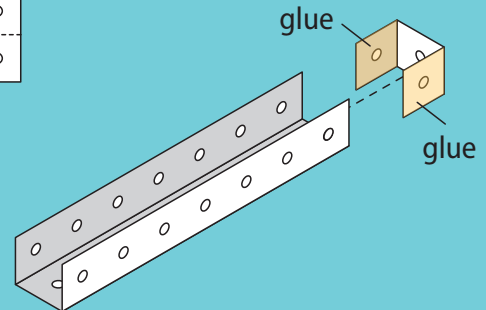

Fold the beams and glue
together as shown.

2 Make the support.

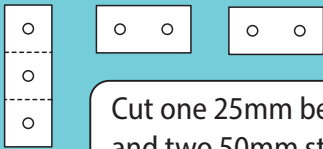

Cut one 25mm beam
and two 50mm strips.

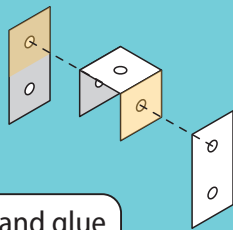

Fold the beam and glue
the strips as shown.

3 Fit the support.

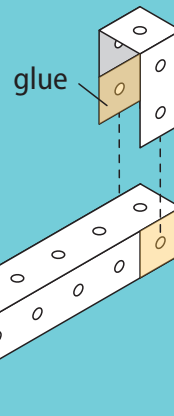

Glue the support to
the chassis as shown.

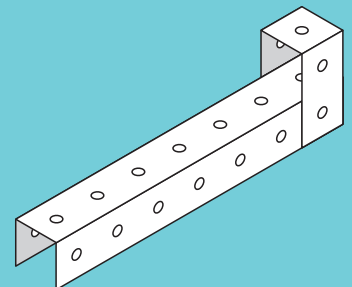

Check the
assembly.

4 Fit the rear axle.

Cut a 60mm axle.

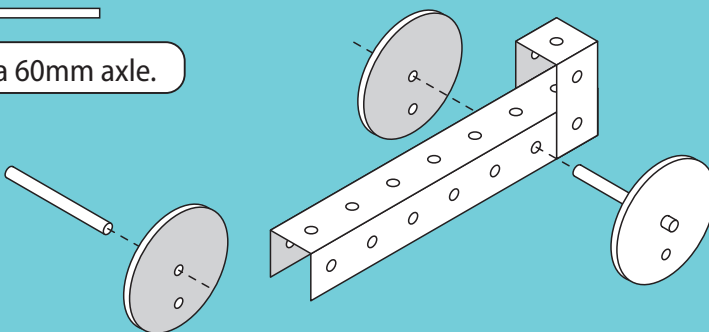

Fit a 60mm wheel
onto the axle.

Pass the axle through the
chassis where shown and
fit a second 60mm wheel.

5 Check the axle.

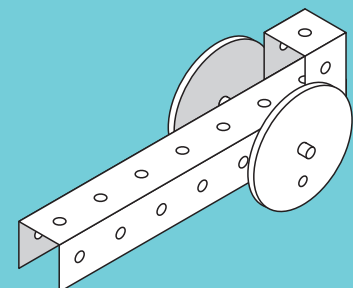

Check there is a gap between the wheels
and the chassis and the wheels are straight.

6 Fit the front wheels.

Cut a 60mm axle.

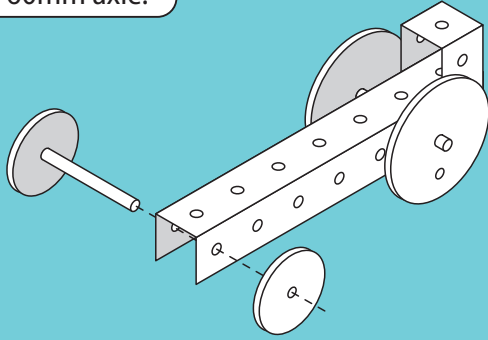

Fit a 40mm wheel to the axle. Pass the axle through the chassis where shown. Fit a second wheel.

7 Glue the wheels.

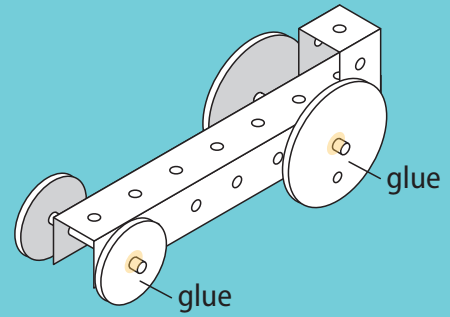

Check there is a gap between the wheels and chassis. Check wheels are straight and glue to axles.

8 Assemble the propeller.

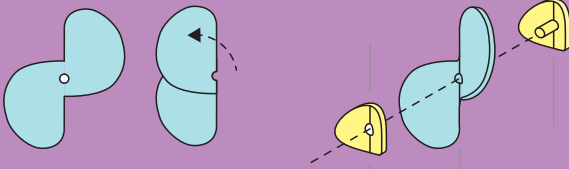

Fold the propeller in half to form a crease.

Position the two parts of the hub as shown. Check the crease in the propeller lines up with the hub and press together.

9 Prepare the motor and battery holder.

Fit the propeller onto the motor axle.



Fit a double sided foam pad under the motor and battery holder.

10 Fit the motor and battery holder.

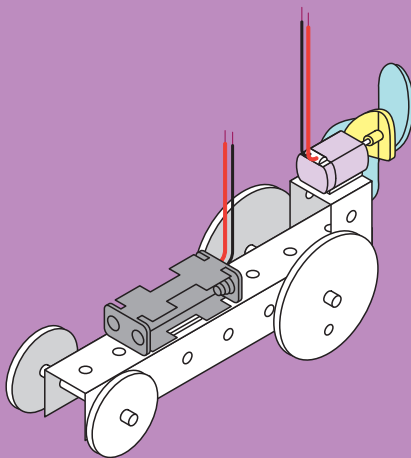

Fit motor and battery holder where shown. Make sure the propeller will not hit the support.

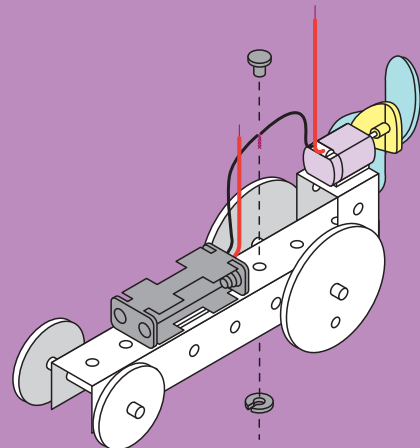

Twist the ends of the two black wires together and use a rivet and collar to fix them to the chassis where shown.

11 Make the switch.

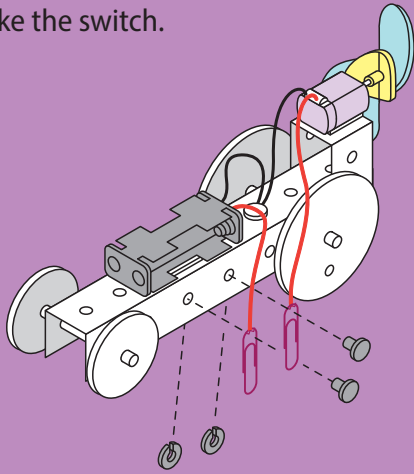

Twist the ends of the red wires around two paper clips. Use a rivet and collar to fix them to the chassis where show.

12 View of the completed circuit.

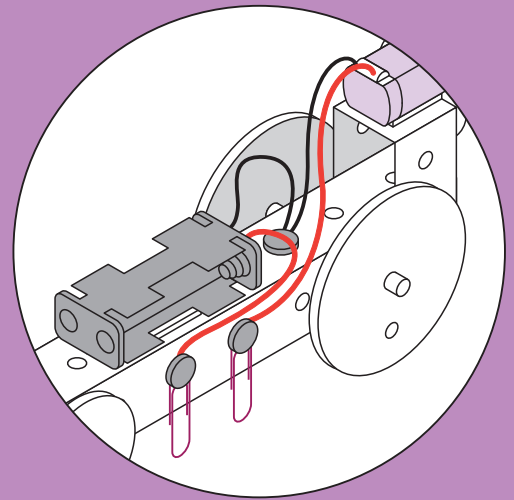

13

Important! Follow these instructions to install the battery.

1. Your teacher or supervising adult must check your model before fitting the battery.
2. Fit the battery under adult supervision.
3. Operate the model under adult supervision.
4. The model must be assembled as shown in the instructions.
5. Do not insert the battery until the model is complete.
6. Check the switch is in the 'off' position before inserting the battery.
7. Requires two 1.5 volt AA batteries.
8. Make sure you insert the battery correctly checking the polarity of the battery is correct. The '+' symbol on the battery must align with the '+' symbol in the battery holder.
9. Make sure the supply terminals in the battery holder are not short circuited.
10. Remove the battery from the model when not in use.
11. Replace exhausted batteries right away to avoid damage.
12. Rechargeable batteries must be removed from the model before recharging.
13. Rechargeable batteries must be recharged under adult supervision.
14. Do not attempt to recharge non-rechargeable batteries.
15. Do not mix old and new batteries.
16. Do not mix alkaline, standard (carbon-zinc) and rechargeable (ni-Cd) batteries.

14 Fit the batteries and body.

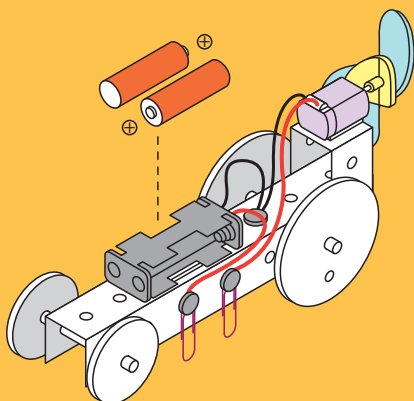

Follow the instructions above to fit the batteries in the battery holder.

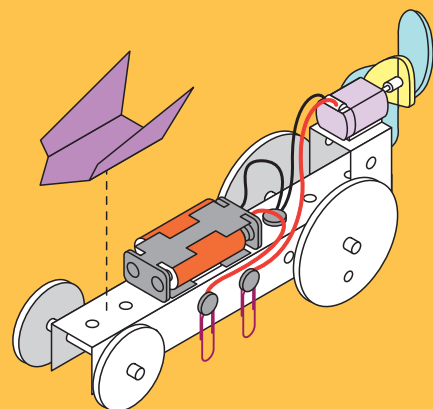

Cut fold and glue the body onto the chassis.

15 Race your Propeller Car!

When you 'close' the switch, electricity flows in a 'circuit' from the battery, through the motor and back to the battery.

As the electricity flows through the motor it generates a 'magnetic field' in wire coils arranged around the motor axle.

The magnetic field in the wire coils is attracted to fixed magnets in the motor and this attraction causes the motor axle to spin.

The motor converts the electrical energy into a mechanical force.

Generating the magnetic field eventually uses up the electricity stored in the battery.

The propeller rotates as the motor axle spins.

As the propeller spins, the angled blades push against the air creating thrust which propels the car.

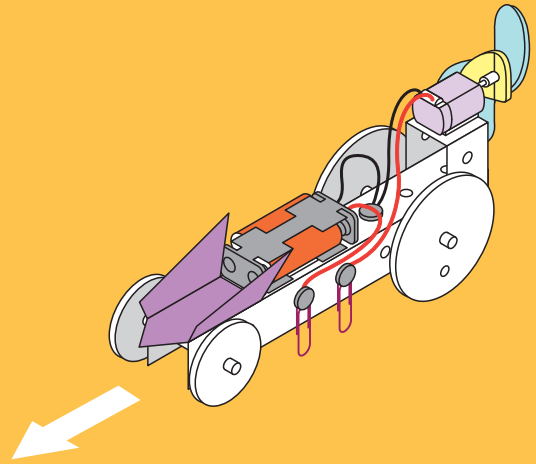

Race your car on a smooth surface.

Card Panels

Print and cut along the solid lines and fold the along dotted lines of the panels or design and make your own!

25mm
25mm